



A CSW Industrials Company

# TRUaire 1444RG Series

## Steel Perforated Face with Round Neck T-Bar Return Air Grille

Model: \_\_\_\_\_ Size: \_\_\_\_\_

**Project Information:**

Job Name: \_\_\_\_\_

Location: \_\_\_\_\_

Engineer: \_\_\_\_\_

Submitted to: \_\_\_\_\_

For:            Reference            Approval            Construction

Submitted by: \_\_\_\_\_

Reference: \_\_\_\_\_

**Submittal Information:**

Approval: \_\_\_\_\_

Date: \_\_\_\_\_

Construction: \_\_\_\_\_

Unit #: \_\_\_\_\_

Drawing #: \_\_\_\_\_

**Construction Options**

R6 Molded Insulated Back

**Available Round Neck Diameters (IN):**

6, 8, 10, 12, 14, 16, 18 and 20

**(Sec. I) Features**

- 51% Free Area Perforated Face
- Hinged Perforated Face
- Pristine White Powder Coat Finish

**(Fig. I) Product Image:**

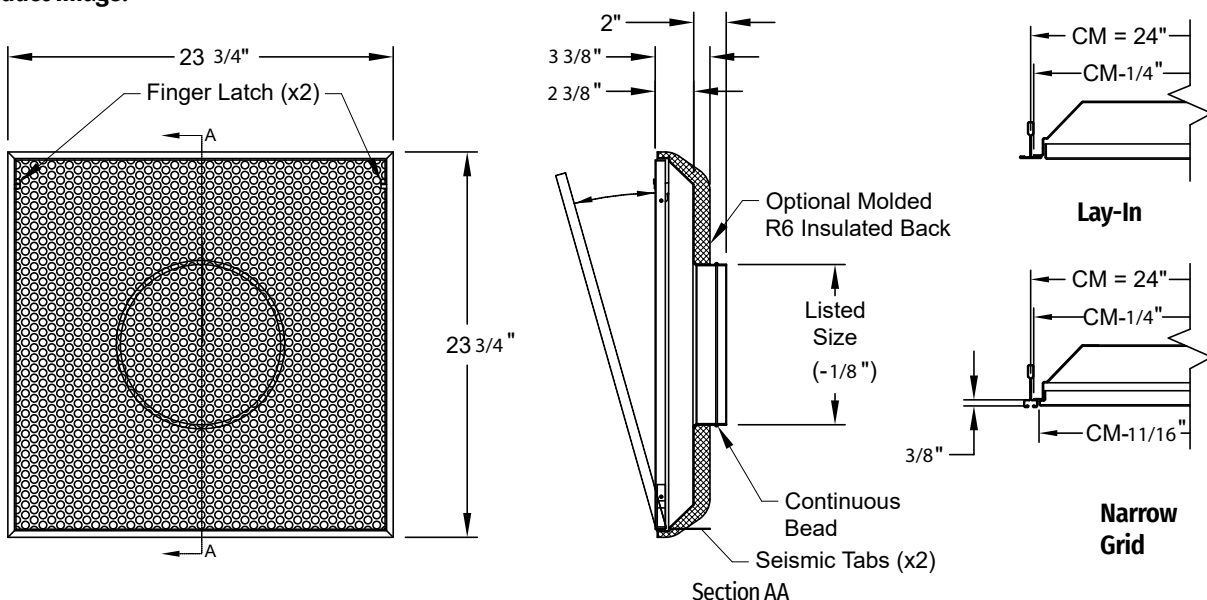

**RectorSeal® • 2601 Spenwick Drive • Houston, TX 77055 • 800-231-3345 • [rectorseal.com](http://rectorseal.com)**

A CSW Industrials Company. RectorSeal, the logos and other trademarks are property of RectorSeal, LLC, its affiliates or its licensors and are protected by copyright, trademark and other intellectual property laws, and may not be used without permission. RectorSeal reserves the right to change specifications without prior notice. ©2023 RectorSeal. All rights reserved. R50956-0323